



## **Innovative screw locking technology**

- Reliable screw locking protects against loosening and unscrewing where high vibration is present
- Settling effects are offset by the high spring effect
- Optimum locking function with elongated hole screw connections



## How it works

The teckentrup detent-edged washer is a screw locking element whose efficacy has been validated over the course of many years. It prevents the failure of screw connections, especially with dynamic loads. With the enhanced NSK washer, you have a locking element that fulfils the increased demands made of screw locking technologies.

In principle, unwanted disengagement of a screw connection is due to two mechanisms – loosening and unscrewing. Loosening is caused by settling effects, which result in a loss of preload

tension. In the case of unscrewing, dynamic loads crosswise to the screw axis affect the thread pitch torque, which can lead to complete loss of preload tension.

Thanks to its combination of knurled surface and flexible geometry, the NSK washer counteracts both loosening and unscrewing, and therefore represents the ultimate solution when it comes to screw locking.



## Inspection procedure compliant with DIN 65151/DIN 25201-4

The vibration test in accordance with DIN 65151 is a qualified procedure for certifying the sureness of screw connections. A dynamic load crosswise to the screw axis establishes the locking action.

The teckentrup company has its own vibration test bench, which is used for regular testing of the NSK washers. The company's products undergo continuous development on the basis of the results obtained.

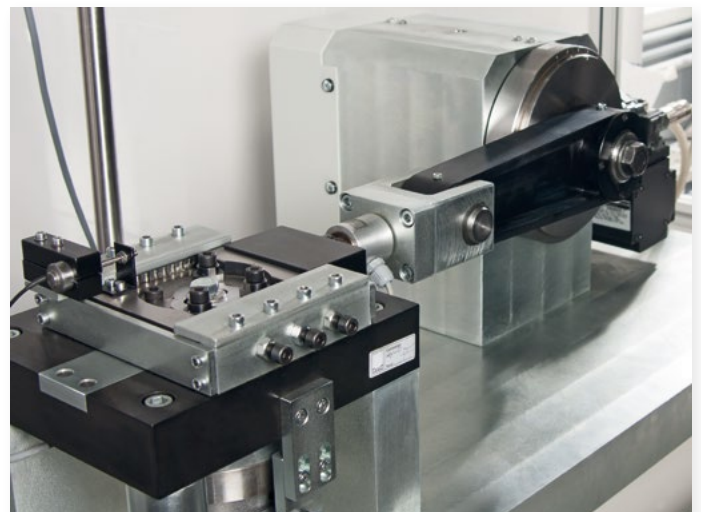





**teckentrup**

## The advantages to you

- Where high vibrations are present, secures against unscrewing and loss of preload tension
- Settling effects are offset by the high spring effect.
- Proven screw locking function at low and high preload forces
- Screw connections with short clamping length are reliably secured when dynamic loads are present.
- Reusable (max 3x)
- Optimum locking function with elongated holescrew connections (NSK B and NSK L)
- Protects the backing (the NSK washer does not turn during assembly)
- Easy assembly, as it is a single-part locking element
- Thanks to its special toothing, no chip formation during fitting
- Low distribution of tightening torques and friction coefficients
- The broad product portfolio provides a solution for almost all applications, plus economic benefits thanks to standardisation. The development of customer-specific custom solutions is also possible.
- The locking elements have been designed on the basis of the tightening torques and constructional standards set out in VDI 2230.
- Available in corrosion-protected special hardened tempered steel or stainless steel. Special materials or surfaces available on request.

# Applications



**Railway Supply Industry**



**Elevators**



**Agricultural Equipment**

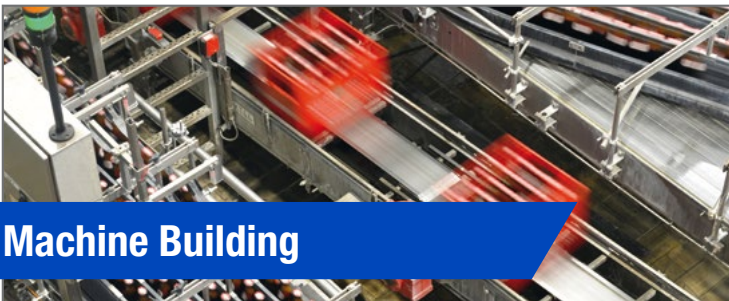

**Machine Building**



**and many other applications...**



teckentrup

## NSK-M (medium): for high-strength connections with normal head contacts

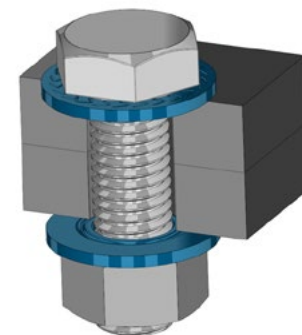
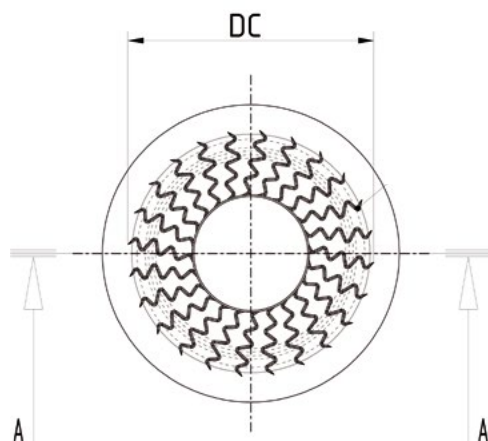
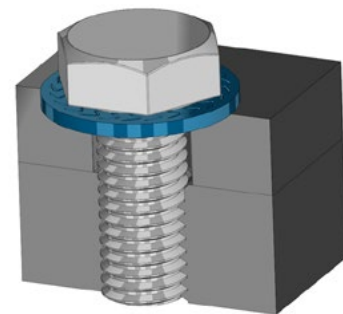
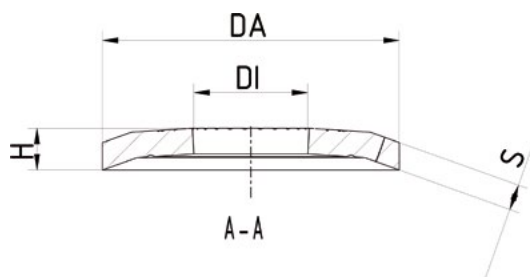

NSK-M	Item no Spring steel with Geomet	Item no Stainless steel A 4 1.4401	DI	DA	S	H	Weight Kg/1000
NSK M4	070010	076010	Ø 4.10+0.48	Ø 10.20-0.40	1.00±0.04	1.45±0.20	0.53
NSK M5	070020	076020	Ø 5.10+0.48	Ø 12.20-0.40	1.20±0.04	1.75±0.20	0.90
NSK M6	070030	076030	Ø 6.10+0.48	Ø 14.20-0.43	1.40±0.04	2.15±0.20	1.40
NSK M8	070040	076040	Ø 8.20+0.58	Ø 18.20-0.52	1.40±0.04	2.70±0.25	2.30
NSK M10	070050	076050	Ø 10.20+0.58	Ø 22.25-0.52	1.60±0.05	3.10±0.25	3.90
NSK M12	070060	076060	Ø 12.40+0.58	Ø 27.25-0.52	1.80±0.05	3.65±0.25	6.50
NSK M14	070070	076070	Ø 14.40+0.58	Ø 30.25-0.62	2.40±0.06	3.90±0.25	10.50
NSK M16	070080	076080	Ø 16.40+0.58	Ø 32.50-0.62	2.50±0.06	4.60±0.30	12.00
NSK M18	070090	076090	Ø 18.50+0.75	Ø 35.00-0.62	3.00±0.07	4.80±0.30	16.30
NSK M20	070100	076100	Ø 21.00+0.75	Ø 40.00-0.62	3.00±0.07	5.00±0.30	22.00
NSK M22	070110	-	Ø 23.00+0.75	Ø 45.00-0.62	3.50±0.07	5.60±0.40	33.00
NSK M24	070120	076120	Ø 25.00+0.75	Ø 50.00-0.62	3.50±0.07	5.80±0.40	41.00
NSK M27	070130	-	Ø 28.00+0.85	Ø 60.00-0.75	4.00±0.08	6.60±0.50	70.00
NSK M30	070140	-	Ø 31.00+0.85	Ø 70.00-0.75	4.50±0.08	7.60±0.50	109.00

# NSK B and NSK L: Reliable screw locking for elongated holes

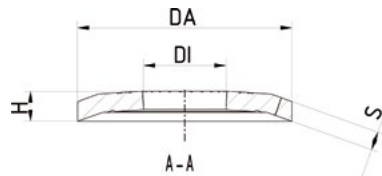
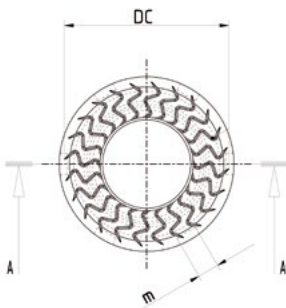

## NSK B (wide) for larger pressure transfer surfaces and elongated hole connections

NSK-B	Item no Spring steel with Geomet	Item no Stainless steel A 4 1.4401	DI	DA	S	H	Weight Kg/1000
NSK B5	070520	076520	Ø 5.10+0.48	Ø 18.20-0.52	1.40±0.04	2.60±0.20	2.50
NSK B6	070530	076530	Ø 6.10+0.48	Ø 18.20-0.52	1.40±0.04	2.60±0.20	2.50
NSK B8	070540	076540	Ø 8.20+0.58	Ø 22.25-0.52	1.90±0.05	3.10±0.25	5.00
NSK B10	070550	076550	Ø 10.20+0.58	Ø 27.25-0.52	2.40±0.05	3.60±0.25	9.40
NSK B12	070560	076560	Ø 12.40+0.58	Ø 32.30-0.62	2.80±0.06	4.80±0.25	15.40
NSK B16	070580	076580	Ø 16,40+0.58	Ø 45,40-0.62	3,50±0.07	5,40±0.30	38,00

## NSK L for elongated hole connections with limited assembly space

NSK-L	Item no Spring steel with Geomet	DI	DA	S	H	Weight Kg/1000
NSK L8	070240	Ø 8.20+0.58	Ø 18.20-0.52	2.40±0.05	3.40±0.25	3.94
NSK L10	070250	Ø 10.20+0.58	Ø 22.25-0.52	2.80±0.06	3.80±0.25	6.83
NSK L12	070260	Ø 12.40+0.58	Ø 27.25-0.52	2.80±0.06	3.85±0.25	10.11
NSK L14	070270	Ø 14.40+0.58	Ø 30.50-0.52	3.50±0.06	4.70±0.25	15.30
NSK L16	070280	Ø 16.40+0.58	Ø 32.50-0.52	3.50±0.07	4.60±0.30	16.80
NSK L20	070300	Ø 21.00+0.58	Ø 40.00-0.52	4.00±0.07	6.00±0.30	28.5



## Further solutions for reliable screw connections:

### NSK-S (narrow) for small head contacts

NSK-S	Item no Spring steel with Geomet	Item no Stainless steel A 4 1.4401	DI	DA	S	H	Weight Kg/1000
NSK S4	070810	076810	Ø 4.10+0.48	Ø 8.20-0.40	1.00±0.04	1.30±0.20	0.30
NSK S5	070820	076820	Ø 5.10+0.48	Ø 10.20-0.40	1.00±0.04	1.50±0.20	0.43
NSK S6	070830	076830	Ø 6.10+0.48	Ø 12.20-0.43	1.20±0.04	1.75±0.20	0.80
NSK S8	070840	076840	Ø 8.20+0.58	Ø 16.20-0.43	1.40±0.04	2.40±0.25	1.70
NSK S10	070850	076850	Ø 10.20+0.58	Ø 20.25-0.52	1.60±0.05	2.75±0.25	3.00
NSK S12	070860	076860	Ø 12.40+0.58	Ø 24.25-0.52	1.60±0.05	3.00±0.25	4.30

### SK-Z for cylinder screws

NSK-Z	Item no Spring steel with Geomet	Item no Stainless steel A 4 1.4401	DI	DA	S	H	Weight Kg/1000
SK Z6	090630	096630	Ø 6.10+0.48	Ø 9.90-0.36	1.40±0.10	1.60+0.20	0.50
SK Z8	090640	096640	Ø 8.20+0.58	Ø 12.70-0.36	1.40±0.10	1.70+0.20	0.90
SK Z10	090650	096650	Ø 10.20+0.58	Ø 16.10-0.36	1.60±0.10	2.00+0.20	1.50
SK Z12	090660	096660	Ø 12.40+0.58	Ø 18.30-0.52	1.80±0.10	2.40+0.20	2.00
SK Z14	090670	096670	Ø 14.40+0.58	Ø 21.40-0.52	2.40±0.10	2.90+0.20	3.70
SK Z16	090680	096680	Ø 16.40+0.58	Ø 24.60-0.52	2.50±0.10	3.10+0.20	5.10

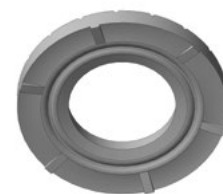
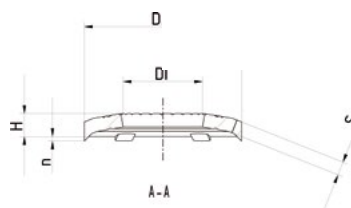
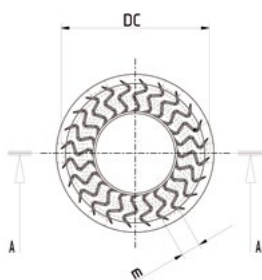

### NSK-K for electroconductive connections

NSK-K	Item no Spring steel with Geomet	Item no Stainless steel A 4 1.4401	DI	DA	S	H	Breite Zahn m	Höhe Zahn n	Weight Kg/1000
NSK K4	070710	076710	Ø 4.10+0.48	Ø 8.20-0.40	1.00±0.03	1.30±0.20	1.20±0.10	0.20+0.20/-0.10	0.50
NSK K5	070720	076720	Ø 5.10+0.48	Ø 10.20-0.40	1.00±0.03	1.50±0.20	2.00±0.10	0.40+0.30/-0.10	0.90
NSK K6	070730	076730	Ø 6.10+0.48	Ø 12.20-0.40	1.20±0.04	1.90±0.20	2.00±0.20	0.40+0.30/-0.10	1.50
NSK K8	070740	076740	Ø 8.20+0.58	Ø 16.20-0.40	1.40±0.04	2.40±0.25	2.00±0.20	0.40+0.30/-0.10	2.00
NSK K10	070750	076750	Ø 10.20+0.58	Ø 20.25-0.50	1.60±0.04	2.75±0.25	2.00±0.20	0.40+0.30/-0.10	3.70
NSK K12	070760	076760	Ø 12.40+0.58	Ø 24.25-0.50	1.60±0.04	3.00±0.25	2.00±0.20	0.40+0.30/-0.10	5.10

Contact washers are used for establishing electroconductive connections (eg for earth and ground connections) of coated equipment parts with coating thicknesses of up to 100 µm.



**Precision sheet metal forming:**

**Forming technology**

**Blanking technology**

**Stamping technology**

**Deep drawing technology**

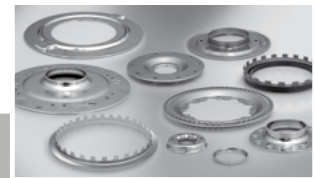
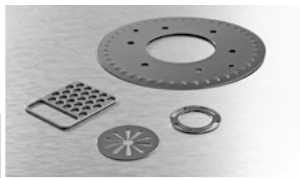

**Contact**

**teckentrup GmbH + Co. KG**  
**Elsetalstr. 6 - 10**  
**D-58849 Herscheid-Hüinghausen**

Tel. : +49 (0) 2357 – 90 80 0  
Fax: +49 (0) 2357 – 34 27  
E-Mail: [info@teckentrup.de](mailto:info@teckentrup.de)  
Internet : [www.teckentrup.de](http://www.teckentrup.de)